



Chapter 31 Inductance

Physics II – Part II
Wen-Bin Jian

Department of Electrophysics, National Chiao Tung University

Calculation of Self-Inductance

Inductance

The calculation of the inductance:

1. calculate generated magnetic field using the current
2. calculate the total magnetic flux
3. the self-inductance is the total magnetic flux divided by the current

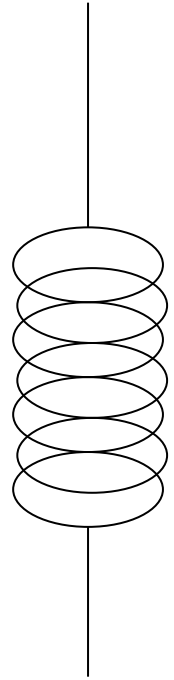

$$\Phi_B = BA = \mu_0 nI (NA) \rightarrow \Phi_B = LI \rightarrow L = \frac{\Phi_B}{I}$$

The induced voltage in the inductor with an inductance L is

$$V_L = -\frac{d\Phi_B}{dt} = -L \frac{dI}{dt}$$

The unit of the inductance is henry (H). $1 \text{ H} = 1 \text{ Wb/A} = 1 \text{ T m}^2/\text{A}$

Calculation of The Current in The RL Circuit

The RL Circuit

Use Kirchoff's rule:

$$\varepsilon_0 - IR - L \frac{dI}{dt} = 0$$

$$\varepsilon_0 - IR = L \frac{dI}{dt} \rightarrow dt = \frac{L dI}{\varepsilon_0 - IR}$$

$$dt = -\frac{L d(\varepsilon_0 - IR)}{R(\varepsilon_0 - IR)} \rightarrow -\frac{R}{L} dt = \frac{d(\varepsilon_0 - IR)}{\varepsilon_0 - IR}$$

$$\int_0^t -\frac{R}{L} dt = \int_0^I \frac{d(\varepsilon_0 - IR)}{\varepsilon_0 - IR} \rightarrow -\frac{R}{L} t = \ln(\varepsilon_0 - IR) - \ln(\varepsilon_0)$$

$$-\frac{R}{L} t = \ln\left(\frac{\varepsilon_0 - IR}{\varepsilon_0}\right) \quad \frac{\varepsilon_0 - IR}{\varepsilon_0} = e^{-\frac{R}{L}t} \quad I(t) = \frac{\varepsilon_0}{R} \left(1 - e^{-\frac{R}{L}t}\right)$$

The current decreases as an exponential decay function. For the exponential decay function, we can define a time constant and here the time constant $\tau = L/R$.

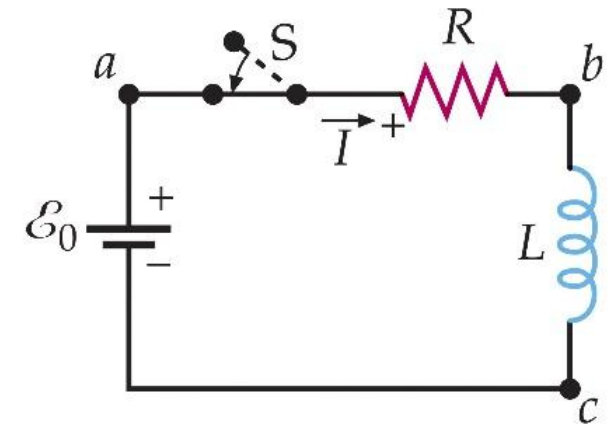

The Energy Stored in The Solenoid

Energy of Magnetic Field

For a self-inductance, the magnetic flux in the inductor is

$$\Phi_m = LI$$

The induced emf is $\varepsilon = -\frac{d}{dt}\Phi_m = -L\frac{dI}{dt}$.

For a changing current in the inductor, the energy consumption is estimated using the power $P = IV = IL\frac{dI}{dt}$.

The total energy for the current increasing from 0 to I is

$$U = \int_0^t P dt = \int_0^t IL \frac{dI}{dt} dt = \int_0^{I(t)} LI dI = \frac{1}{2} LI^2$$

The Energy Stored in The Solenoid

Energy of Magnetic Field

Considering a solenoid of cross-sectional area A , a number of coils per unit length n , and a length l , the current in the solenoid is I .

The magnetic field inside the solenoid is $B = \mu_0 n I$ and the magnetic flux in the solenoid is $\Phi_m = n l A \mu_0 n I$.

The self-inductance of the solenoid is $L = \frac{\Phi_m}{I} = l A \mu_0 n^2$.

For a solenoid with current I , the energy stored in it is $U = \frac{1}{2} L I^2 = \frac{1}{2} l A \mu_0 n^2 I^2$.

The energy stored in the inductor can be taken as the energy of the generated magnetic fields in the solenoid, thus we can calculate the volumetric energy density of magnetic fields.

$$u_B = \frac{U}{V} = \frac{U}{Al} = \frac{l A \mu_0 n^2 I^2}{2Al} = \frac{\mu_0 n^2 I^2}{2} = \frac{\mu_0^2 n^2 I^2}{2\mu_0} = \frac{B^2}{2\mu_0} \leftrightarrow u_E = \frac{\epsilon_0 E^2}{2}$$

Mutual Inductance

When two current loops are coupled together, the current change in one loop will induce an emf in the other loop.



The mutual inductance between the two loops is decided by the common space between Loops 1 & 2.

The current I_1 in Loop 1 gives flux to Loop 2: $\Phi_2 = I_1 M_{12}$

The current I_2 in Loop 2 gives flux to Loop 1: $\Phi_1 = I_2 M_{21}$

The mutual inductance is only depended on the spatial arrangement of the two loops thus $M_{12} = M_{21}$.

Oscillations in an LC Circuit

A charged capacitor is connected with an inductor. When the loop is closed, the charge and current will exhibit oscillations.

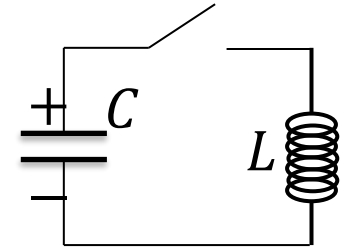

Use the Kirchhoff's rule on the circuit, we have

$$-L \frac{dI}{dt} - \frac{Q}{C} = 0 \rightarrow L \frac{d^2 Q}{dt^2} + \frac{Q}{C} = 0$$

Let $Q(t) = A \sin(Bt + D)$ be a solution and put it into the equation:

$$-LB^2 A \sin(Bt + D) + \frac{1}{C} A \sin(Bt + D) = 0 \rightarrow -LB^2 + \frac{1}{C} = 0$$

$$B = \frac{1}{\sqrt{LC}} \rightarrow Q(t) = A \sin\left(\frac{t}{\sqrt{LC}} + D\right) \& I(t) = \frac{A}{\sqrt{LC}} \cos\left(\frac{t}{\sqrt{LC}} + D\right)$$

$$U = U_C + U_L = \frac{Q^2}{2C} + \frac{LI^2}{2} = \frac{A^2}{2C} \sin^2\left(\frac{t}{\sqrt{LC}} + D\right) + \frac{L A^2}{2 LC} \cos^2\left(\frac{t}{\sqrt{LC}} + D\right) = \frac{A^2}{2C}$$

Oscillations in an LC Circuit

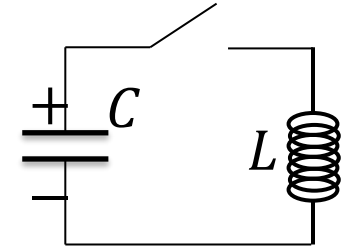

There are alternative calculations since

$$e^{i\theta} = \cos \theta + i \sin \theta, \cos \theta = \frac{e^{i\theta} + e^{-i\theta}}{2}, \sin \theta = \frac{e^{i\theta} - e^{-i\theta}}{2i}$$

We can use a guess solution $Q(t) = Ae^{Bt}$ to solve $L \frac{d^2Q}{dt^2} + \frac{Q}{C} = 0$

Put the guess solution into the differential equation, we get

$$LB^2 Ae^{Bt} + Ae^{Bt}/C = 0 \rightarrow (LB^2 + 1/C)Ae^{Bt} = 0$$

$$B = \pm \frac{i}{\sqrt{LC}} \rightarrow Q(t) = A_1 e^{it/\sqrt{LC}} + A_2 e^{-it/\sqrt{LC}}$$

This solution is exactly the same as that you have derived

$$Q(t) = A \sin \left(\frac{t}{\sqrt{LC}} + D \right)$$

LC Circuit versus Harmonic Oscillation

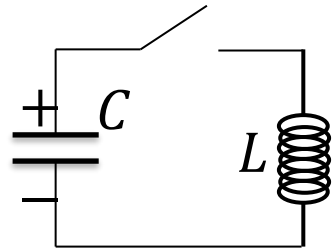

$$L \frac{d^2 Q}{dt^2} + \frac{Q}{C} = 0$$

$$Q(t) = Q_{max} \sin\left(\frac{t}{\sqrt{LC}} + \varphi\right)$$

$$m \frac{d^2 x}{dt^2} + kx = 0$$

$$x(t) = A \sin(\sqrt{k/m}t + \varphi)$$

$$Q(t) \rightarrow x(t), L \rightarrow m, \frac{1}{C} \rightarrow k, \frac{1}{\sqrt{LC}} \rightarrow \sqrt{k/m}$$

$$I(t) = \frac{dQ}{dt} \rightarrow v(t) = \frac{dx}{dt}$$

$$\varepsilon = L \frac{dI}{dt} \rightarrow F = ma, V_C = -\frac{Q}{C} \rightarrow F_{spring} = -kx$$

$$\frac{1}{2} LI^2 + \frac{Q^2}{2C} = const \rightarrow \frac{1}{2} mv^2 + \frac{1}{2} kx^2 = const$$

Oscillations in an LC Circuit

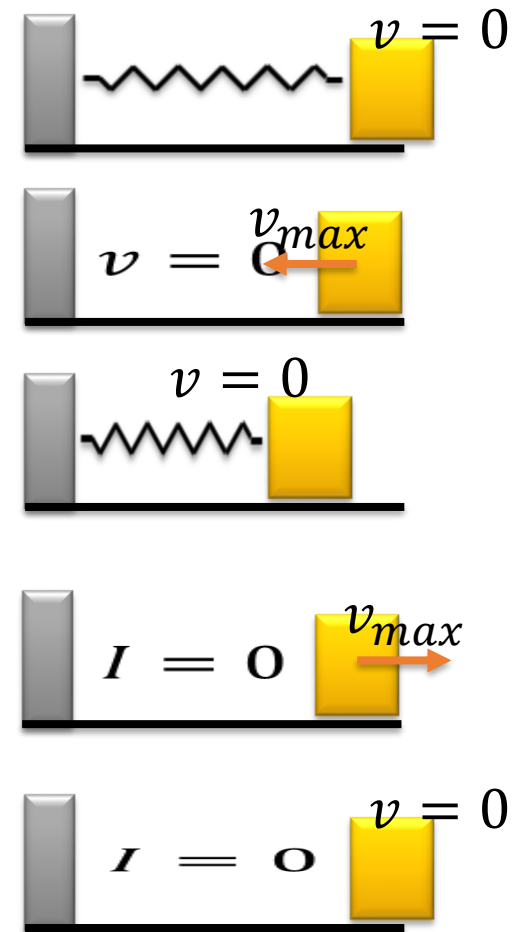
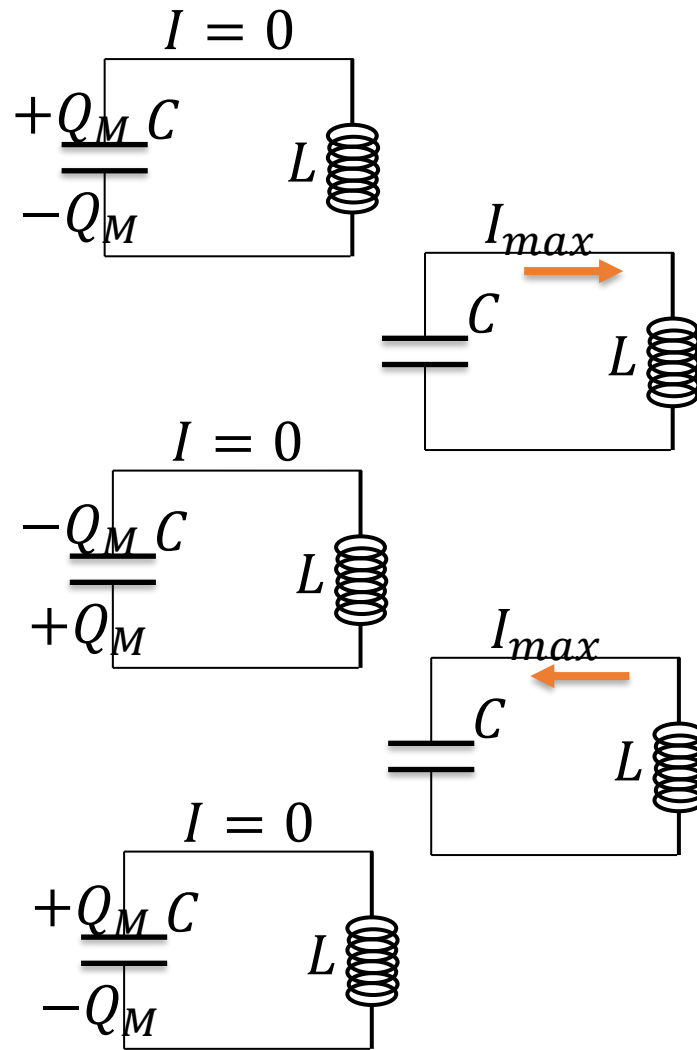

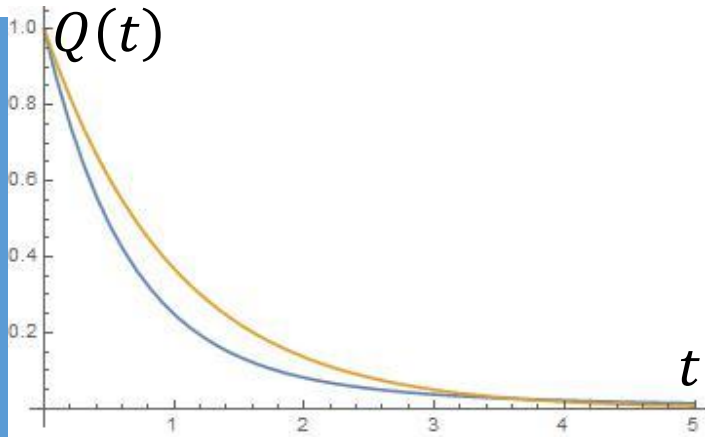

The RLC Circuit

Use the Kirchhoff's rule on the circuit, we have

$$-L \frac{dI}{dt} - \frac{Q}{C} - IR = 0 \rightarrow L \frac{d^2 Q}{dt^2} + R \frac{dQ}{dt} + \frac{Q}{C} = 0$$

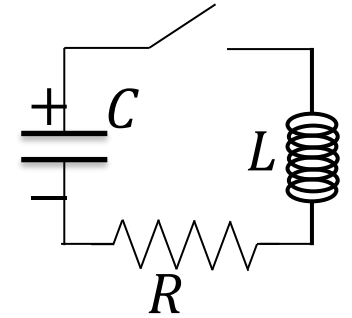

Let's use a guess solution of $Q(t) = Ae^{Bt}$.

$$LB^2 Ae^{Bt} + RBAe^{Bt} + \frac{1}{C} Ae^{Bt} = 0 \rightarrow (LB^2 + RB + 1/C) Ae^{Bt} = 0$$

$$B = \frac{-R}{2L} \pm \frac{\sqrt{R^2 - 4L/C}}{2L} = -\frac{R}{2L} \pm \sqrt{(R/2L)^2 - 1/LC}$$

1. Overdamped oscillation ($\frac{R^2}{4L^2} - \frac{1}{LC} > 0$):

$$Q(t) = A_1 e^{-\frac{R}{2L}t + \sqrt{(R/2L)^2 - 1/LC}t} + A_2 e^{-\frac{R}{2L}t - \sqrt{(R/2L)^2 - 1/LC}t}$$

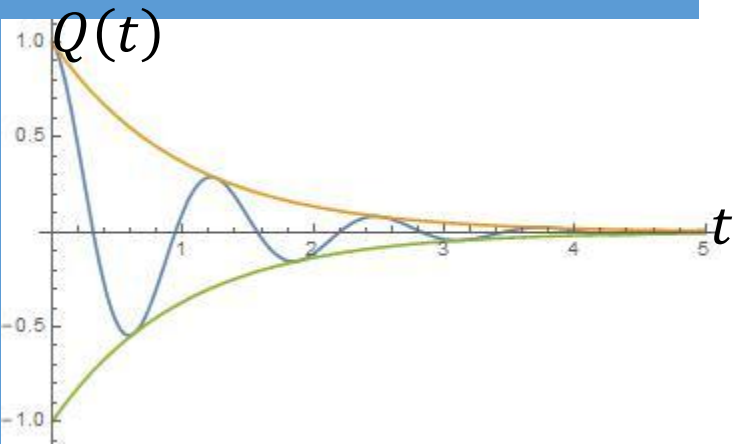

The RLC Circuit

2. Critically damped oscillation ($\frac{R^2}{4L^2} - \frac{1}{LC} = 0$):

$$Q(t) = Ae^{-\frac{R}{2L}t} \rightarrow e^{-\frac{R}{2L}t}(A_1 + A_2t)$$

3. Underdamped oscillation ($\frac{R^2}{4L^2} - \frac{1}{LC} < 0$):

$$Q(t) = A_1 e^{-\frac{R}{2L}t + i\sqrt{1/LC - (R/2L)^2}t} + A_2 e^{-\frac{R}{2L}t - i\sqrt{1/LC - (R/2L)^2}t}$$

$$Q(t) = e^{-\frac{R}{2L}t} \left(A_1 e^{i\sqrt{1/LC - (R/2L)^2}t} + A_2 e^{-i\sqrt{1/LC - (R/2L)^2}t} \right)$$

$$Q(t) = e^{-\frac{R}{2L}t} \left(A \sin \left(\sqrt{1/LC - (R/2L)^2}t + \varphi \right) \right), \omega_0 = 1/\sqrt{LC}$$

$$Q(t) = e^{-\frac{R}{2L}t} \left(A \sin \left(\sqrt{\omega_0^2 - (R/2L)^2}t + \varphi \right) \right)$$

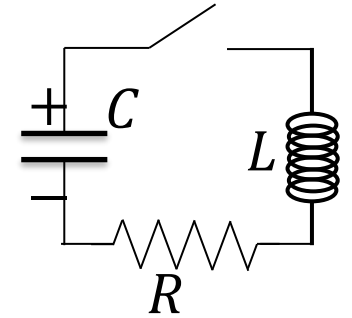

The Calculation of Inductance

Model a long coaxial cable as two thin, concentric, cylindrical conducting shells of radii a and b and length l . The conducting shells carry the same current in opposite directions. Calculate the inductance L of this cable.

Let the current be I in the two concentric conducting shells.

The magnetic field due to the current in the inner shell is

$$2\pi rB = \mu_0 I \rightarrow B = \frac{\mu_0 I}{2\pi r}$$

The total magnetic flux through the area with a length l and a width from $r = a$ to $r = b$ is

$$\Phi_B = \int_a^b \left(\frac{\mu_0 I}{2\pi r} \right) l dr = \frac{\mu_0 I l}{2\pi} \ln \left(\frac{b}{a} \right) \rightarrow L = \frac{\mu_0 l}{2\pi} \ln \left(\frac{b}{a} \right)$$

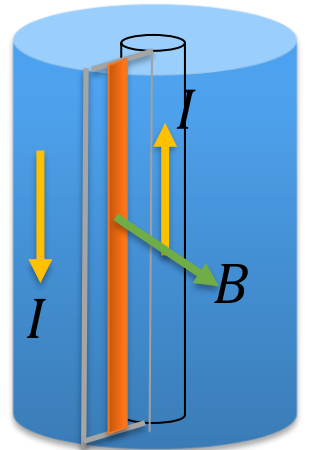

Examples

The Calculation of Inductance

The toroid in the right figure consists of N turns and has a rectangular cross section. Its inner and outer radii are a and b , respectively. Find the inductance of the toroid.

$$2\pi rB = \mu_0 NI$$

$$B = \frac{\mu_0 NI}{2\pi r}$$

$$\Phi_B = h \int_a^b \frac{\mu_0 NI}{2\pi r} dr = \frac{\mu_0 NIh}{2\pi} \ln\left(\frac{b}{a}\right)$$

$$\Phi_{B,total} = N \frac{\mu_0 NIh}{2\pi} \ln\left(\frac{b}{a}\right) = \frac{\mu_0 N^2 Ih}{2\pi} \ln\left(\frac{b}{a}\right) = LI$$

$$L = \frac{\mu_0 N^2 h}{2\pi} \ln\left(\frac{b}{a}\right)$$

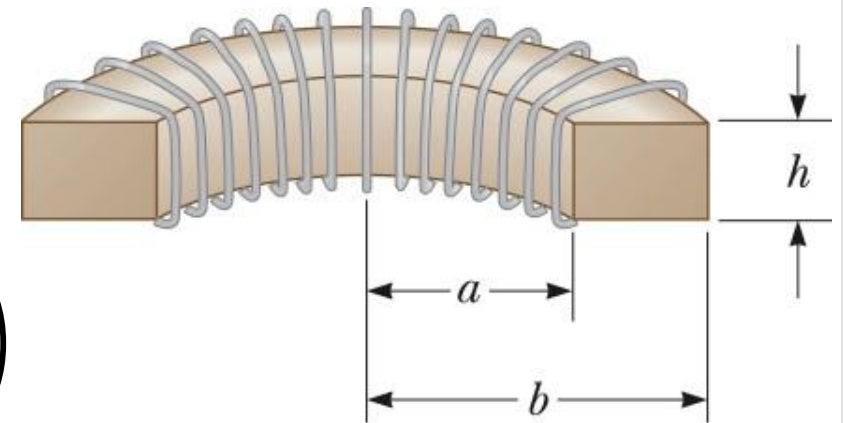

Examples

The Calculation of Inductance

Examples

Two parallel wires carry currents of equal magnitude in opposite directions for non-digital TV signals from an antenna. The center-to-center separation of the wires is w , and a is their radius. Assume w is large enough compared with a that the wires carry the current uniformly distributed over their surface and negligible magnetic field exists inside the wires. Calculate the inductance of a length x of this type of lead-in.

$$2\pi rB = \mu_0 I \rightarrow B = \frac{\mu_0 I}{2\pi r}$$

$$\phi = x \int_a^{w-a} \frac{\mu_0 I}{2\pi r} dr = \frac{\mu_0 I x}{2\pi} \ln \left(\frac{w-a}{a} \right)$$

$$\Phi = 2 \frac{\mu_0 I x}{2\pi} \ln \left(\frac{w-a}{a} \right) = LI$$

$$L = \frac{\mu_0 x}{\pi} \ln \left(\frac{w-a}{a} \right)$$

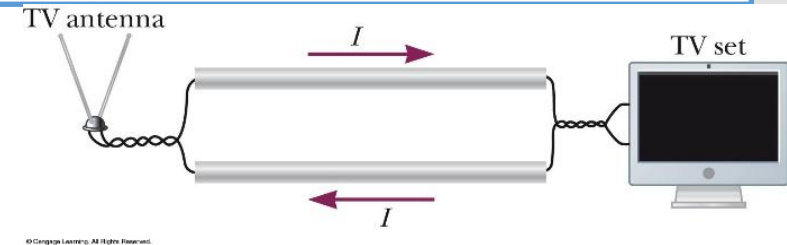

The Calculation of Inductance

Find the total energy dissipated in the resistor R , when the current in the inductor decreases from its initial value of I_0 to 0?

Use the Kirchoff's rule: $-L \frac{dI}{dt} - IR = 0$

$$\frac{LdI}{dt} = -IR \rightarrow \frac{dI}{I} = -\frac{R}{L} dt$$

$$\int_{I_0}^I \frac{dI}{I} = -\frac{R}{L} \int_0^t dt \rightarrow \ln\left(\frac{I}{I_0}\right) = -\frac{R}{L} t \rightarrow I = I_0 e^{-\frac{R}{L} t}$$

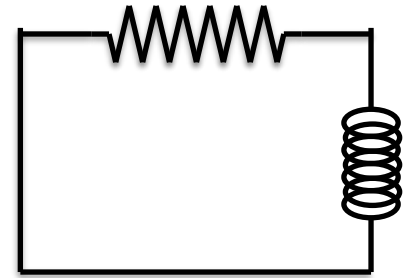

The power dissipated on the resistor is $P = I^2 R = RI_0^2 e^{-2\frac{R}{L} t}$.

The total dissipated energy is $U = \int_0^\infty I_0^2 e^{-2\frac{R}{L} t} R dt = \frac{1}{2} LI_0^2$.

Examples

The Calculation of Inductance

A certain region of space contains a uniform magnetic field of 0.030 T and a uniform electric field of 2.0×10^6 N/C. Find (a) the total volumetric energy density of the electric and magnetic fields.

$$u = u_E + u_B = \frac{1}{2} \epsilon_0 E^2 + \frac{B^2}{2\mu_0}$$

$$u = \frac{1}{2} (8.85 \times 10^{-12}) (2.0 \times 10^6)^2 + \frac{(0.03)^2}{2(4\pi \times 10^{-7})} = 17.7 + 358$$

$$u = 375.8 \text{ J/m}^3$$

Examples

Examples

Two solenoids with radii of r_1 and r_2 and the numbers of loops N_1 and N_2 are arranged coaxially. The two solenoids are of the same length l . Please calculate their mutual inductances.

Assume the current in Solenoid 2 is I_2

$$B = \mu_0 \frac{N_2}{l} I_2$$

The magnetic flux in Solenoid 1 is $\Phi_1 = N_1 \mu_0 \frac{N_2}{l} I_2 \pi r_1^2 = I_2 M_{21}$

Assume the current in Solenoid 1 is I_1

$$B = \mu_0 \frac{N_1}{l} I_1$$

The magnetic flux in Solenoid 2 is $\Phi_2 = N_2 \mu_0 \frac{N_1}{l} I_1 \pi r_2^2 = I_1 M_{12}$

$$M_{12} = M_{21} = \mu_0 N_1 N_2 \pi r_1^2 / l$$

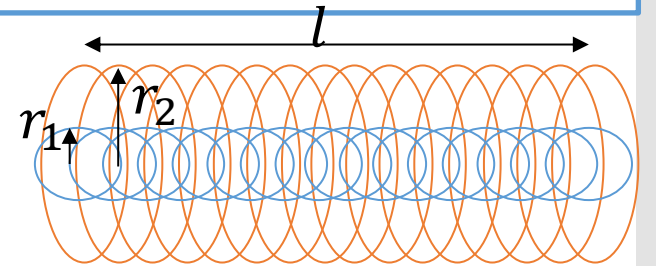

Examples

A capacitor of $2 \mu\text{F}$ is fully charged by a voltage of 10 V . The capacitor is connected with an inductor of $2 \mu\text{H}$. Please calculate the oscillation frequency and the peak current in the inductor-capacitor system.

For an LC circuit, the natural oscillating angular speed is

$$\omega = \frac{1}{\sqrt{LC}} = \frac{1}{\sqrt{(2 \times 10^{-6})(2 \times 10^{-6})}} = 5 \times 10^5$$

$$\rightarrow f = \frac{\omega}{2\pi} = 7.96 \times 10^4 \text{ Hz}$$

The maximum charge stored in the capacitor is estimated using the charge voltage: $Q_M = CV = 2 \times 10^{-5} \text{ C}$

Use the energy conservation to find the peak current of the LC

$$\text{oscillating system: } \frac{CV^2}{2} = \frac{Q_M^2}{2C} = \frac{LI_M^2}{2} \rightarrow I_M = \frac{Q_M}{\sqrt{LC}} = 10 \text{ A}$$

Examples

Two inductors having inductances L_1 and L_2 are connected in parallel. The mutual inductance between the two inductors is M . Determine the equivalent inductance L_{eq} for the system.

L : self inductance

M : mutual inductance

$$i = i_1 + i_2$$

$$V = L_1 \frac{di_1}{dt} + M \frac{di_2}{dt} = L_2 \frac{di_2}{dt} + M \frac{di_1}{dt}$$

$$(L_1 - M) \frac{di_1}{dt} = (L_2 - M) \frac{di_2}{dt}$$

$$\frac{di_1/dt}{di_2/dt} = \frac{L_2 - M}{L_1 - M}$$

$$\frac{di_1}{dt} + \frac{di_2}{dt} = \frac{di}{dt} \quad \frac{di_1}{dt} = \frac{L_2 - M}{L_1 + L_2 - 2M} \frac{di}{dt} \quad \frac{di_2}{dt} = \frac{L_1 - M}{L_1 + L_2 - 2M} \frac{di}{dt}$$

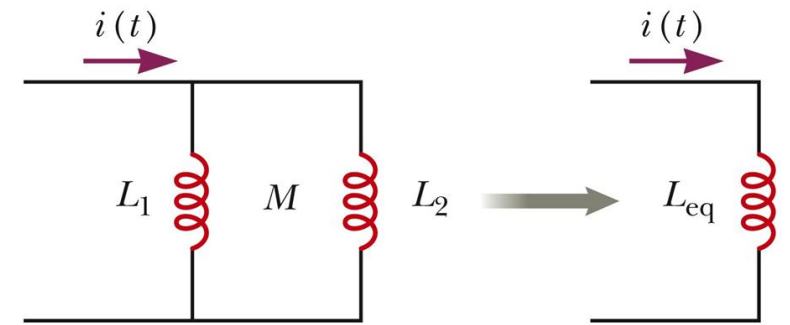

Examples

Two inductors having inductances L_1 and L_2 are connected in parallel. The mutual inductance between the two inductors is M . Determine the equivalent inductance L_{eq} for the system.

$$\frac{di_1}{dt} = \frac{L_2 - M}{L_1 + L_2 - 2M} \frac{di}{dt}$$

$$\frac{di_2}{dt} = \frac{L_1 - M}{L_1 + L_2 - 2M} \frac{di}{dt}$$

$$V = L_1 \frac{di_1}{dt} + M \frac{di_2}{dt} = \frac{L_1(L_2 - M)}{L_1 + L_2 - 2M} \frac{di}{dt} + \frac{(L_1 - M)M}{L_1 + L_2 - 2M} \frac{di}{dt}$$

$$V = \frac{L_1L_2 - M^2}{L_1 + L_2 - 2M} \frac{di}{dt} = L_{eq} \frac{di}{dt}$$

$$L_{eq} = \frac{L_1L_2 - M^2}{L_1 + L_2 - 2M}$$